

HC-D 15-ESTC

Order No.: 1772324

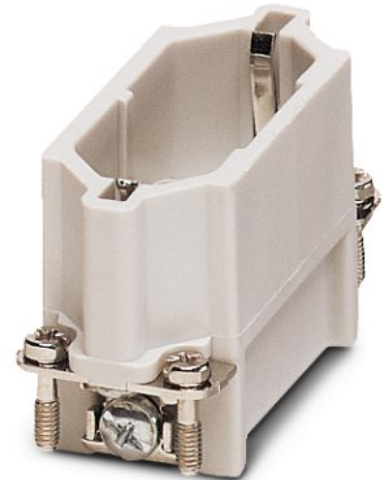

<http://eshop.phoenixcontact.de/phoenix/treeViewClick.do?UID=1772324>

HEAVYCON male insert, D15 series, 15-pos., crimp connection

Commercial data	
EAN	4017918036997
Pack	10 Pcs.
Customs tariff	85366990
Weight/Piece	0.03633 KG
Catalog page information	Page 357 (PC-2007)

Product notes

WEEE/RoHS-compliant since:
03/01/2006



<http://www.download.phoenixcontact.com>
Please note that the data given here has been taken from the online catalog. For comprehensive information and data, please refer to the user documentation. The General Terms and Conditions of Use apply to Internet downloads.

Technical data

General data	
Note	For HC-D15 housing, crimp contacts CK1,6-ED (crimp contacts not included in scope of supply)
Connection systems	Crimp connection

Ambient temperature (operation)	-40 °C ... 125 °C (including heating up of contacts)
Pollution degree	3
Surge voltage category	III
Test voltage	4 kV AC
Constructional and testing regulations	DIN VDE 0627/86
	DIN VDE 0110/02.79
	DIN VDE 0110-1/04.97
	IEC 60664-1, DIN IEC 60512
	IEC 60352
Number of positions	15
Insertion/withdrawal cycles	≥ 500
Design	D15
Connection in acc. with standard	IEC / EN
Conductor cross section	0.14 mm ² ... 2.5 mm ²
Connection cross section AWG	26 ... 14
Stripping length of the individual wire	8 mm
	6 mm (2.5 mm ²)

Material data

Inflammability class acc. to UL 94	V0
Contact material	Copper alloy
Contact surface material	Ag (alternatively Au)
Contact carrier material	PA

Electrical characteristics

Rated voltage (III/3)	250 V
Rated surge voltage	4 kV
Rated current	10 A

Certificates / Approvals

Approval logo



CSA

Nominal voltage U_N	300 V
Nominal current I_N	10 A
AWG/kcmil	22-16

UL

Nominal voltage U_N	600 V
Nominal current I_N	10 A
AWG/kcmil	22-16
Certification	CSA, GOST, UL

Drawings

Diagram

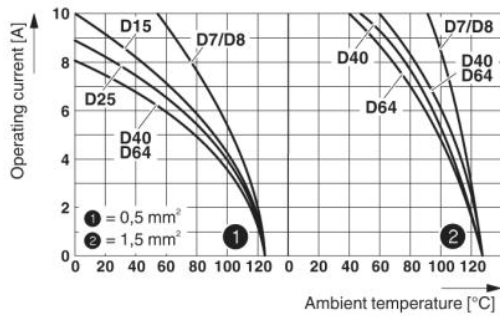

Dimensioned drawing

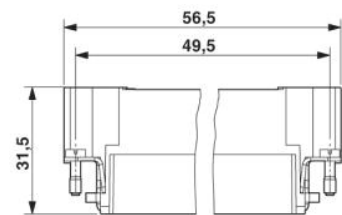

Male insert

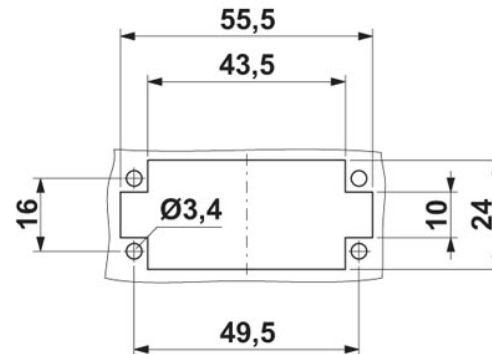
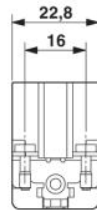

Panel cutout

Schematic diagram

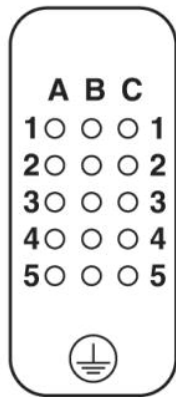
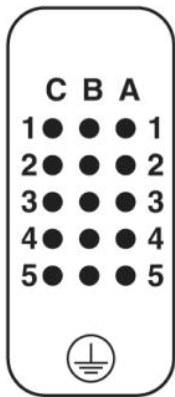

1 = male insert
2 = female insert

Address

PHOENIX CONTACT GmbH & Co. KG
Flachsmarktstr. 8
32825 Blomberg, Germany
Phone +49 5235 3 00
Fax +49 5235 3 41200
<http://www.phoenixcontact.com>



© 2008 Phoenix Contact
Technical modifications reserved;